

HPSG Signature for the Grammar of English

June 23, 2006

Contents

1	Signs	2
2	Words	3
	Verbs	4
	Nouns	4
	Determiners	4
	Attributive adjectives	5
3	Phrases	5
	Head-Complement Phrase	7
	Head-Subject Phrase	7
	Head-Specifier Phrase	7
	Head-Adjunct Phrase	8
	Simple-Head-Adjunct Phrase	8
	Head-rel Phrase	8
	Wh-rel Clause	9
	Subject-Wh-relative Clause	9
	Non-subject-Wh-relative Clause	9
4	Constraints	9
	The Head Feature Principle	9
	The Content Principle	9
	The Quantifier Amalgamation Principle – Final version	10
	The Quantifier Inheritance Principle	10

1 Signs

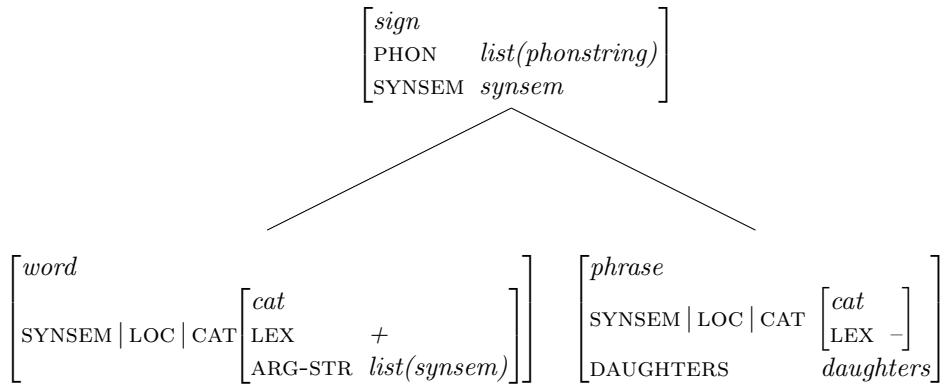
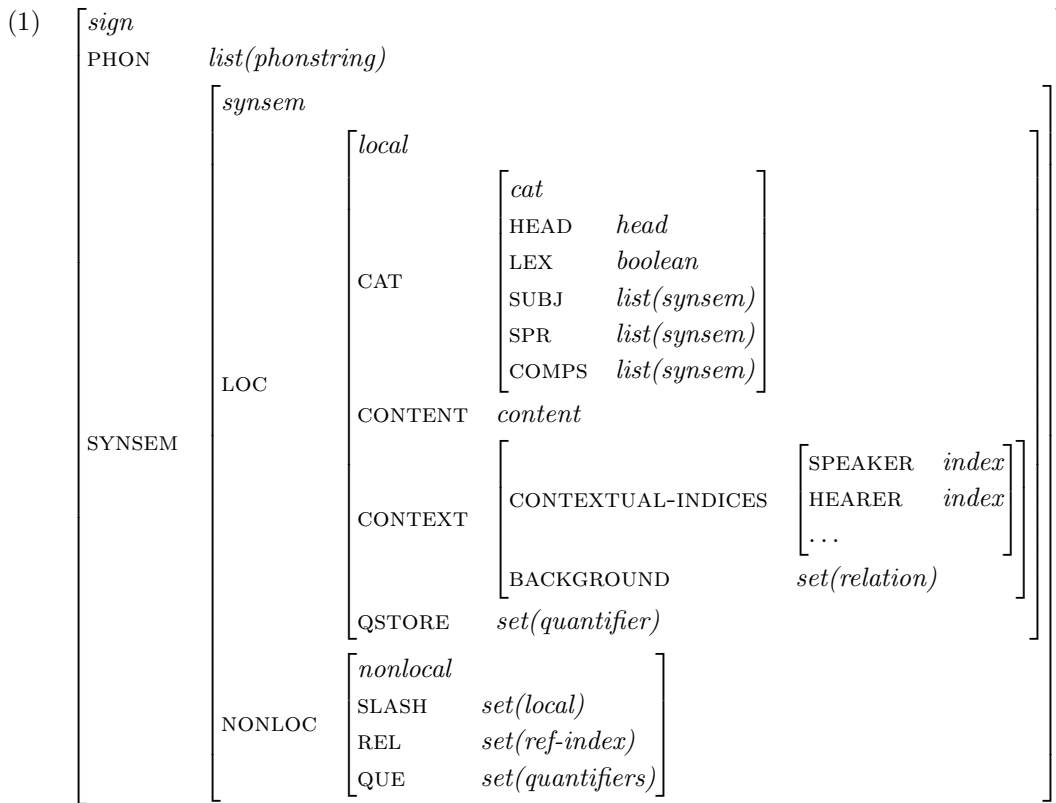

Figure 1: The sortal hierarchy for *sign*



2 Words

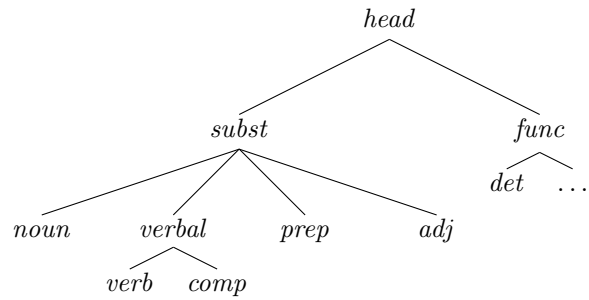
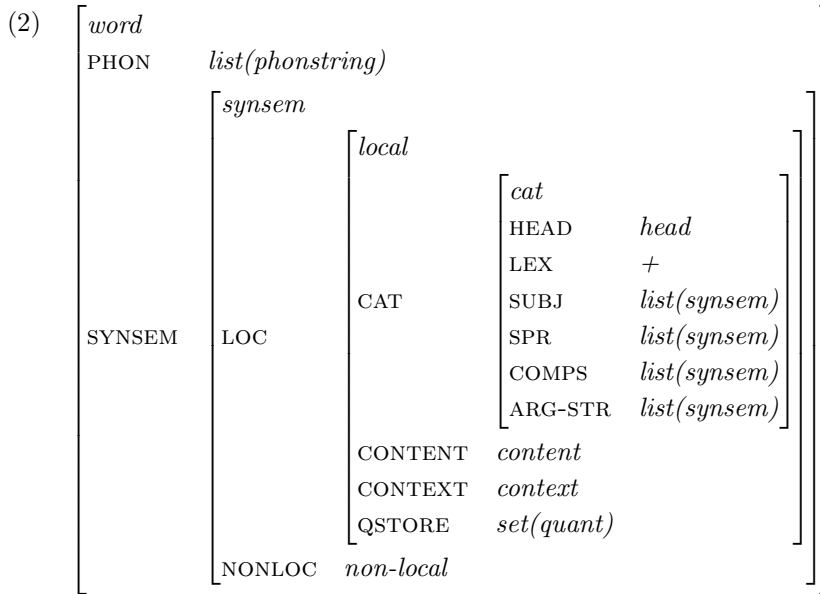

Figure 2: The *head* sortal hierarchy.

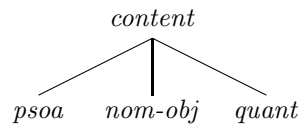

Figure 3: The *content* sortal hierarchy.

Verbs

$$\left[\begin{array}{l} \text{CAT} \\ \text{CONTENT} \end{array} \left[\begin{array}{l} \text{HEAD} \left[\begin{array}{l} \textit{verb} \\ \text{VFORM} \quad \textit{vform} \\ \text{AUX} \quad \textit{bool} \\ \text{INV} \quad \textit{bool} \\ \text{MOD} \quad \textit{synsem} \vee \textit{none} \end{array} \right] \\ \text{SPR} \quad \textit{elist} \end{array} \right] \left[\begin{array}{l} \textit{psoa} \\ \text{QUANTS} \quad \langle \rangle \\ \text{NUCLEUS} \quad \textit{relation} \end{array} \right] \right]$$

Nouns

$$\left[\begin{array}{l} \text{CAT} \\ \text{CONTENT} \end{array} \left[\begin{array}{l} \text{HEAD} \left[\begin{array}{l} \textit{noun} \\ \text{CASE} \quad \textit{case} \end{array} \right] \\ \text{INDEX} \left[\begin{array}{l} \textit{nom-obj} \\ \text{INDEX} \left[\begin{array}{l} \textit{index} \\ \text{PER} \quad \textit{per} \\ \text{NUM} \quad \textit{num} \\ \text{GEND} \quad \textit{gend} \end{array} \right] \end{array} \right] \\ \text{RESTRICTION} \quad \textit{set}(\textit{psoa}) \end{array} \right]$$

Determiners

$$\left[\begin{array}{l} \text{CAT} \\ \text{CONT} \\ \text{QSTORE} \end{array} \left[\begin{array}{l} \text{HEAD} \left[\begin{array}{l} \textit{det} \\ \text{SPEC} \quad \text{N}'[\text{CONT} \boxed{1}] \end{array} \right] \\ \boxed{2} \left[\begin{array}{l} \textit{all-quant} \\ \text{REST-IND} \quad \boxed{1} \end{array} \right] \\ \{\boxed{2}\} \end{array} \right]$$

Attributive adjectives

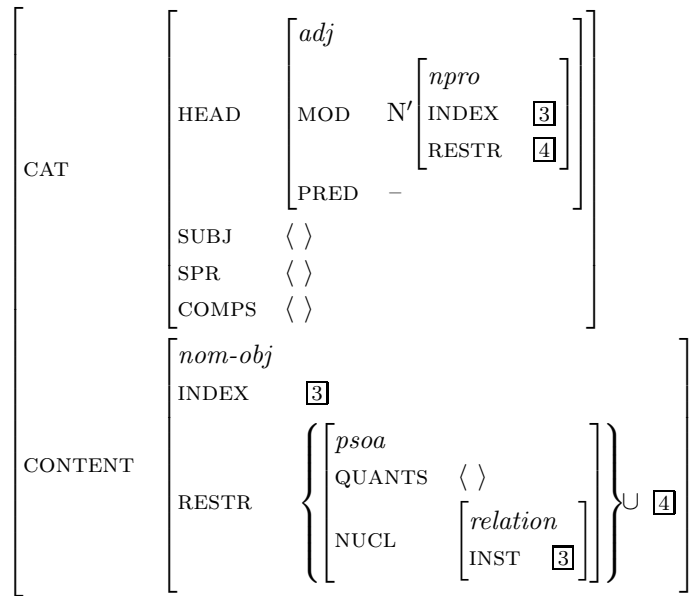

3 Phrases

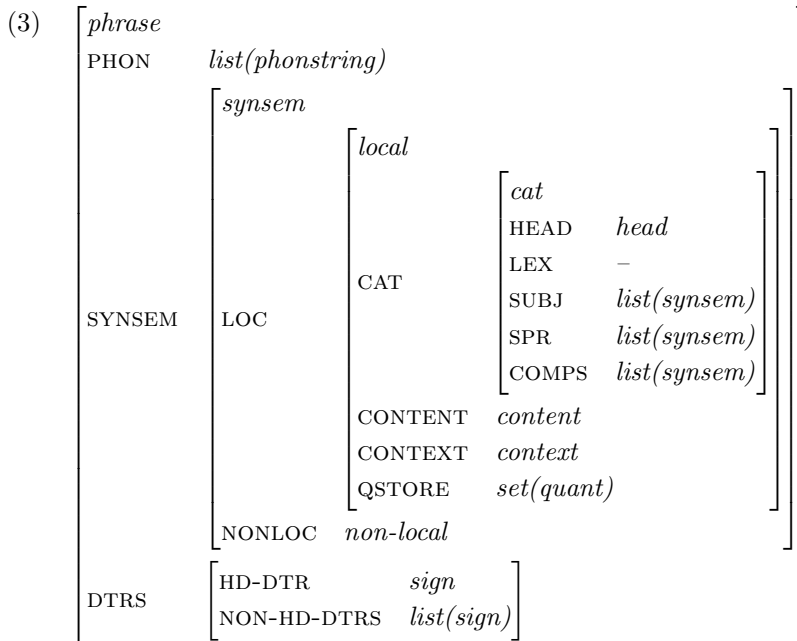

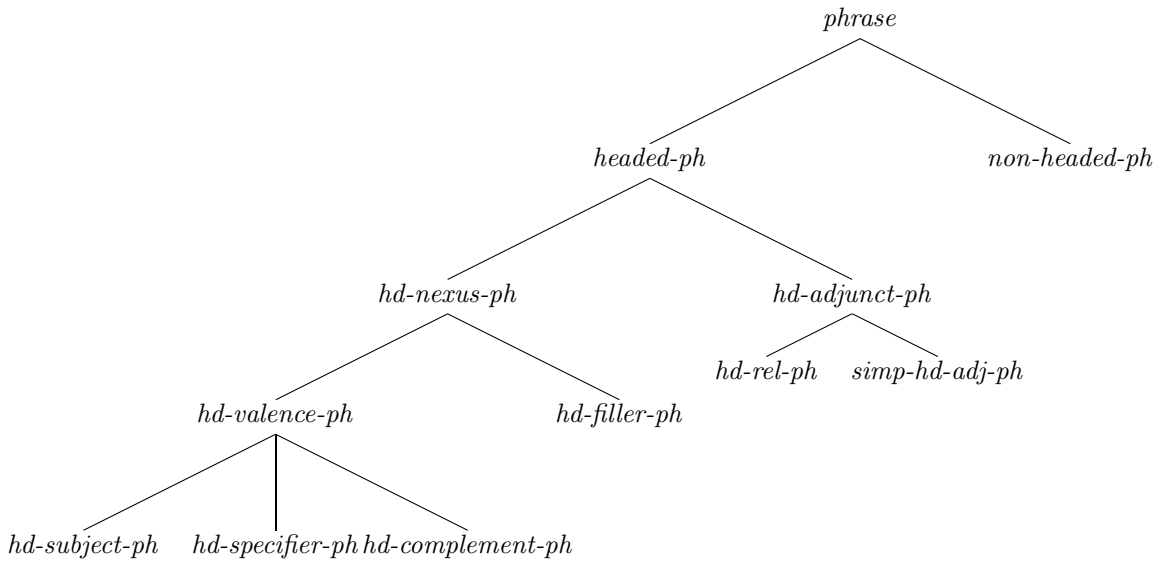

Figure 4: The sortal hierarchy for *phrase*

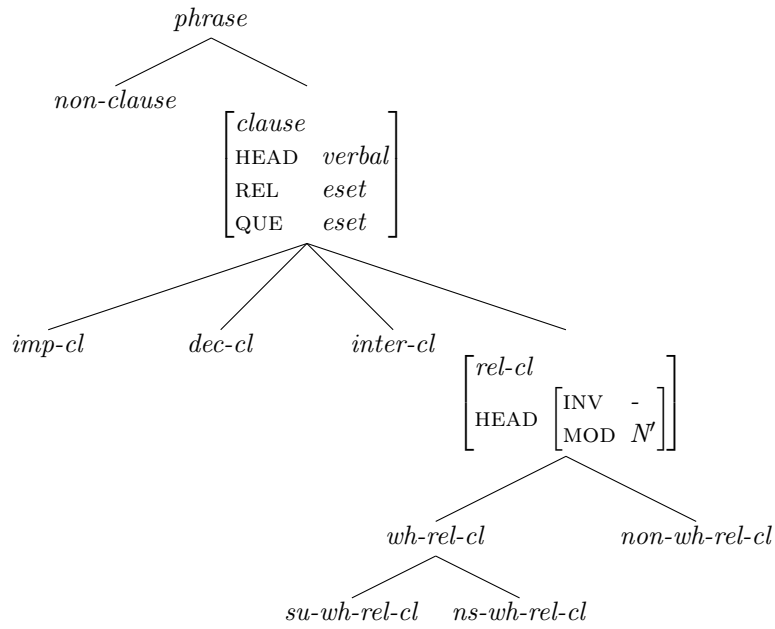

Figure 5: Revised sortal hierarchy for clausality

Head-Complement Phrase

$$hd-comp-ph \Rightarrow \left[\begin{array}{l} \left[\begin{array}{l} \text{SYNSEM} \mid \dots \left[\begin{array}{l} \text{SUBJ} \quad \boxed{1} \\ \text{SPR} \quad \boxed{2} \\ \text{COMPS} \quad \langle \rangle \end{array} \right] \end{array} \right] \\ \text{DTRS} \left[\begin{array}{l} \text{HD-DTR} \left[\begin{array}{l} \textit{word} \\ \text{SYNSEM} \mid \dots \left[\begin{array}{l} \text{SUBJ} \quad \boxed{1} \\ \text{SPR} \quad \boxed{2} \\ \text{COMPS} \quad \langle \boxed{3}, \dots, \boxed{n} \rangle \end{array} \right] \end{array} \right] \\ \text{NON-HD-DTRS} \quad \langle [\text{SYNSEM} \boxed{3}], \dots, [\text{SYNSEM} \boxed{n}] \rangle \end{array} \right] \end{array} \right]$$

Head-Subject Phrase

$$hd-subj-ph \Rightarrow \left[\begin{array}{l} \left[\begin{array}{l} \text{PHON} \quad \boxed{1} \oplus \boxed{2} \\ \text{SUBJ} \quad \langle \rangle \\ \text{SPR} \quad \boxed{3} \\ \text{COMPS} \quad \boxed{4} \end{array} \right] \\ \text{HEAD-DTR} \left[\begin{array}{l} \textit{phrase} \\ \text{PHON} \quad \boxed{2} \\ \text{SUBJ} \quad \langle \boxed{5} \rangle \\ \text{SPR} \quad \boxed{3} \langle \rangle \\ \text{COMPS} \quad \boxed{4} \langle \rangle \end{array} \right] \\ \text{NON-HD-DTRS} \quad \langle \left[\begin{array}{l} \textit{sign} \\ \text{PHON} \quad \boxed{1} \\ \text{SYNSEM} \quad \boxed{5} \end{array} \right] \rangle \end{array} \right]$$

Head-Specifier Phrase

$$hd-spr-ph \Rightarrow \left[\begin{array}{l} \left[\begin{array}{l} \text{PHON} \quad \boxed{1} \oplus \boxed{2} \\ \text{SPR} \quad \langle \rangle \end{array} \right] \\ \text{HD-DTR} \left[\begin{array}{l} \textit{phrase} \\ \text{PHON} \quad \boxed{2} \\ \text{SPR} \quad \langle \boxed{3} \rangle \end{array} \right] \\ \text{NON-HD-DTRS} \quad \langle \left[\begin{array}{l} \textit{phrase} \\ \text{PHON} \quad \boxed{1} \\ \text{SYNSEM} \quad \langle \boxed{3} \rangle \end{array} \right] \rangle \end{array} \right]$$

Head Filler Phrase

$$hd\text{-}filler\text{-}ph \Rightarrow \left[\begin{array}{l} \text{NONLOC} \quad \left[\text{SLASH} \quad \{ \} \right] \\ \text{HD-DTR} \quad \left[\begin{array}{l} \text{HEAD} \quad \textit{verb} \\ \text{SUBJ} \quad \langle \rangle \\ \text{COMPS} \quad \langle \rangle \\ \text{LEX} \quad - \\ \text{SLASH} \quad \{ \boxed{1} \} \end{array} \right] \\ \text{NON-HD-DTR} \quad \langle \left[\text{LOC} \quad \boxed{1} \right] \rangle \end{array} \right]$$

Head-Adjunct Phrase

$$hd\text{-}adj\text{-}ph \Rightarrow \left[\begin{array}{l} \text{HD-DTR} \quad \left[\begin{array}{l} \textit{phrase} \\ \text{SYNSEM} \quad \boxed{1} \end{array} \right] \\ \text{NON-HD-DTRS} \quad \left\langle \left[\begin{array}{l} \textit{phrase} \\ \text{HEAD} \quad \left[\text{MOD} \quad \boxed{1} \right] \end{array} \right] \right\rangle \end{array} \right]$$

Simple-Head-Adjunct Phrase

$$simp\text{-}hd\text{-}adj\text{-}ph \Rightarrow \left[\begin{array}{l} \textit{hd-adj-ph} \\ \text{CONTENT} \quad \boxed{1} \\ \text{NON-HD-DTRS} \quad \left\langle \left[\begin{array}{l} \textit{phrase} \\ \text{CONT} \quad \boxed{1} \end{array} \right] \right\rangle \end{array} \right]$$

Head-rel Phrase

$$hd\text{-}rel\text{-}ph \Rightarrow \left[\begin{array}{l} \text{HEAD} \quad \textit{noun} \\ \text{CONT} \quad \left[\begin{array}{l} \text{INDEX} \quad \boxed{1} \\ \text{RESTR} \quad \boxed{2} \uplus \{ \boxed{3} \} \end{array} \right] \\ \text{HD-DTR} \quad \left[\begin{array}{l} \text{INDEX} \quad \boxed{1} \\ \text{RESTR} \quad \boxed{2} \end{array} \right] \\ \text{NON-HD-DTR} \quad \left\langle \left[\begin{array}{l} \text{SUBJ} \quad \langle \rangle \\ \text{CONT} \quad \left[\text{NUCLEUS} \quad \boxed{3} \right] \end{array} \right] \right\rangle \end{array} \right]$$

Wh-rel Clause

$$wh-rel-cl \Rightarrow \left[\begin{array}{l} hd-filler-ph \\ HD-DTR \left[\begin{array}{l} MOD \quad N' \boxed{1} \\ SUBJ \quad list(gap-ss) \end{array} \right] \\ NON-HD-DTR \quad \langle [REL \quad \{\boxed{1}\}] \rangle \end{array} \right]$$

Subject-Wh-relative Clause

$$su-wh-rel-cl \Rightarrow \left[\begin{array}{l} HD-DTR \left[\begin{array}{l} SUBJ \quad \langle \begin{array}{l} gap-ss \\ LOC \quad \boxed{1} \end{array} \rangle \end{array} \right] \\ REL \quad \{\boxed{4}\} \\ NON-HD-DTR \quad \langle \begin{array}{l} LOC \quad \boxed{1} \\ REL \quad \{\boxed{4}\} \end{array} \rangle \end{array} \right]$$

Non-subject-Wh-relative Clause

$$ns-wh-rel-cl \Rightarrow \left[HD-DTR \quad [SUBJ \quad \langle \rangle] \right]$$

4 Constraints**The Head Feature Principle**

$$headed-ph \Rightarrow \left[\begin{array}{l} HEAD \quad \boxed{1} \\ HD-DTR \quad [HEAD \quad \boxed{1}] \end{array} \right]$$

The Content Principle

$$hd-nexus-ph \Rightarrow \left[\begin{array}{l} CONTENT \quad \boxed{1} \\ HD-DTR \quad [CONTENT \quad \boxed{1}] \end{array} \right]$$

Principle of Contextual Consistency

The CONTEXT|BACKGROUND value of a given phrase is the union of the CONTEXT|BACKGROUND values of the daughters.

The Slash Amalgamation Constraint

$$word \Rightarrow \left[\begin{array}{l} \text{LOC} \\ \text{NONLOC} \end{array} \left[\begin{array}{l} \text{ARG-STR} \langle [\text{SLASH } \boxed{1}], \dots, [\text{SLASH } \boxed{n}] \rangle \\ \text{BIND} \quad \boxed{2} \\ \text{SLASH} \quad (\boxed{1} \uplus \dots \uplus \boxed{n}) - \boxed{2} \end{array} \right] \right]$$

The Argument Realisation Constraint

$$word \Rightarrow \left[\begin{array}{l} \text{SUBJ} \quad \boxed{1} \\ \text{SPR} \quad \boxed{2} \\ \text{COMPS} \quad \boxed{3} \textit{list}(\textit{canon-ss}) \\ \text{ARG-STR} \quad \boxed{1} \oplus \boxed{2} \oplus (\boxed{3} \circ \textit{list}(\textit{gap-ss})) \end{array} \right]$$

Slash Inheritance Principle - Revised version

$$hd\text{-valence-}ph \Rightarrow \left[\begin{array}{l} \text{SLASH} \quad \boxed{1} \\ \text{HD-DTR} \quad \left[\text{SLASH } \boxed{1} \right] \end{array} \right]$$

The Quantifier Amalgamation Principle – Final version

$$word \Rightarrow \left[\begin{array}{l} \text{ARG-STR} \quad \langle [\text{QSTORE } \boxed{1}], \dots, [\text{QSTORE } \boxed{n}] \rangle \\ \text{QSTORE} \quad (\boxed{1} \uplus \dots \uplus \boxed{n}) - \boxed{2} \\ \text{CONTENT} \quad \left[\begin{array}{l} \textit{psoa} \\ \text{QUANTS} \quad \textit{order}(\boxed{2}) \end{array} \right] \end{array} \right]$$

The Quantifier Inheritance Principle

$$head\text{-nexus-}ph \Rightarrow \left[\begin{array}{l} \text{QUANTS} \quad \boxed{1} \\ \text{HD-DTR} \quad \left[\text{QUANTS} \quad \boxed{1} \right] \end{array} \right]$$